



## SDV-C1H-TX

SDVoE Full 4K 10G AV over IP CAT-Based  
Small Form Factor Transmitter

**OPERATION MANUAL**



**HDMI®**  
HIGH-DEFINITION MULTIMEDIA INTERFACE

The terms HDMI, HDMI High-Definition Multimedia Interface, and the HDMI Logo are trademarks or registered trademarks of HDMI Licensing Administrator, Inc.

## **DISCLAIMERS**

The information in this manual has been carefully checked and is believed to be accurate. CYP (UK) Ltd assumes no responsibility for any infringements of patents or other rights of third parties which may result from its use.

CYP (UK) Ltd assumes no responsibility for any inaccuracies that may be contained in this document. CYP (UK) Ltd also makes no commitment to update or to keep current the information contained in this document.

CYP (UK) Ltd reserves the right to make improvements to this document and/or product at any time and without notice.

## **COPYRIGHT NOTICE**

No part of this document may be reproduced, transmitted, transcribed, stored in a retrieval system, or any of its part translated into any language or computer file, in any form or by any means—electronic, mechanical, magnetic, optical, chemical, manual, or otherwise—without express written permission and consent from CYP (UK) Ltd.

© Copyright 2026 by CYP (UK) Ltd.

All Rights Reserved.

Version 1.1

## **TRADEMARK ACKNOWLEDGMENTS**

All products or service names mentioned in this document may be trademarks of the companies with which they are associated.

---



## SAFETY PRECAUTIONS

Please read all instructions before attempting to unpack, install or operate this equipment and before connecting the power supply. Please keep the following in mind as you unpack and install this equipment:

- Always follow basic safety precautions to reduce the risk of fire, electrical shock and injury to persons.
- To prevent fire or shock hazard, do not expose the unit to rain, moisture or install this product near water.
- Never spill liquid of any kind on or into this product.
- Never push an object of any kind into this product through any openings or empty slots in the unit, as you may damage parts inside the unit.
- Do not attach the power supply cabling to building surfaces.
- Use only the supplied power supply unit (PSU). Do not use the PSU if it is damaged.
- Do not allow anything to rest on the power cabling or allow any weight to be placed upon it or any person walk on it.
- To protect the unit from overheating, do not block any vents or openings in the unit housing that provide ventilation and allow for sufficient space for air to circulate around the unit.
- Please completely disconnect the power when the unit is not in use to avoid wasting electricity.

## VERSION HISTORY

REV.	DATE	SUMMARY OF CHANGE
<b>Ver 1.00</b>	2025/12/15	Initial Release

# CONTENTS

<b>1. Introduction</b> .....	<b>1</b>
<b>2. Applications</b> .....	<b>1</b>
<b>3. Package Contents</b> .....	<b>1</b>
<b>4. System Requirements</b> .....	<b>2</b>
<b>5. Features</b> .....	<b>2</b>
<b>6. Operation Controls and Functions</b> .....	<b>3</b>
6.1 Front Panel .....	3
6.2 Rear Panel .....	4
6.3 Basic AV Extension .....	5
6.3.1 Point-to-Point (One Way) .....	5
6.4 Advanced AV Extension .....	6
6.4.1 IP Master Controller .....	6
6.4.2 Configuration Examples .....	7
<b>7. Connection Diagram</b> .....	<b>9</b>
<b>8. Specifications</b> .....	<b>10</b>
8.1 Technical Specifications .....	10
8.2 Video Specifications .....	11
8.3 Audio Specifications .....	13
8.3.1 Digital Audio .....	13
8.4 Cable Specifications .....	14
<b>9. Acronyms</b> .....	<b>15</b>

---



## 1. INTRODUCTION

This SDV-C1H-TX is designed for high-quality, IP routable, AV extension up to 4K@60 4:4:4 with minimum latency. The use of 10-Gigabit Ethernet ports, and Cat.6A cable allows transmission of the video signal up to 100m.

Advanced HDMI content such as HDR (High Dynamic Range), 10-bit colour and multichannel HD Bitstream audio can be transmitted through the network.

The small and compact size design enhances the flexibility of installation. Additionally, the specially engineered source preview functionality added to this hardware platform increases its utility when controlled remotely. When combined with the optional IP Master Controller (the SDV-CS8) or control software, the functionality of the transmitter expands exponentially. Multiple transmitters and receivers may be combined with one or more 10-Gigabit Ethernet switches and the units can be used together to form a distributed video matrix, a multiviewer system, or a video wall system adding to their flexibility in large event installations.

The SDV-C1H-TX can be powered directly via PoE when connected through Cat.6A to a 10-Gigabit Ethernet switch that supports PoE (802.3af), allowing for great installation flexibility. Advanced control such as firmware update can also be performed conveniently through the SDV-CS8 Controller or control software.

## 2. APPLICATIONS

- /// Video and audio over Cat.6A extension
- /// Point-to-Point Secure Video Conferencing
- /// Hotel or convention centre display
- /// Multi-monitor broadcast
- /// Distributed video matrix system
- /// Distributed video wall system

## 3. PACKAGE CONTENTS

- /// 1× 4K60 HDMI AV over IP Transmitter
- /// 1× 5V/2.6A DC Power Adapter
- /// 1× Operation Manual

## 4. SYSTEM REQUIREMENTS

- /// HDMI source equipment such as a media player, video game console, PC, or set-top box
- /// The use of Premium High Speed HDMI cables, and industry standard Cat.6A, or Cat.7 Ethernet cable is highly recommended
- /// A 10-Gigabit Ethernet network switch with jumbo frame and IGMP snooping support is required for distributed video systems (Optional, required for multi-transmitter/receiver systems)
- /// IP Master Controller or PC control software to configure distributed matrix, video wall, or multi-view systems (Optional)

## 5. FEATURES

- /// HDMI 2.0 and DVI 1.0 compatible
- /// HDCP 2.2 and HDCP 1.x compliant
- /// 4K@60 Extension up to 100m (with Cat.6A cable)
- /// Unit can be powered directly by PoE when connected to a 10 Gigabit Ethernet (10GbE) switch that provides PoE (802.3af)
- /// Video preview support when used with the SDV-CS8 Master Controller
- /// Supports the use of an external control center (SDV-CS8 Master Controller) or control software to provide expanded functionality
- /// IP routable with minimum latency
- /// Supports independent breakaway A/V matrix switching with minimum latency, video wall generation, and multi-view compositing
- /// Supports pass-through of 10/12-bit HDR sources (Point-to-Point and Bypass modes only)
- /// Supports pass-through of audio formats including LPCM (up to 8 channels), Bitstream and HD Bitstream
- /// Ultra-light compression, lossless for most content

## 6. OPERATION CONTROLS AND FUNCTIONS

### 6.1 Front Panel

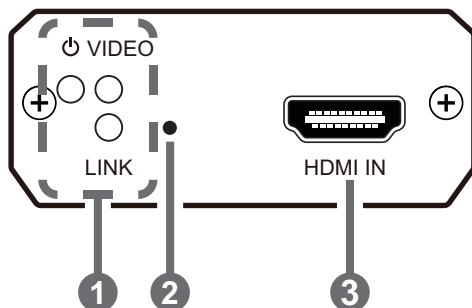

#### 1 STATUS LED BLOCK:

- **POWER LED:** This LED will illuminate to indicate the unit is on and receiving power or flash in update mode.
- **VIDEO LED:** This LED indicates video streaming activity over the Cat.6A/7 port. It will illuminate green when a video signal is being transmitted. When no video is active the LED will remain off, even if the streaming connection is valid.
- **LINK LED:** This LED will illuminate and blink to indicate data transmission activity across the Cat.6A/7 streaming connection.

2 **Reset Pinhole:** Press this recessed button to reboot the unit and all settings will be returned to the factory defaults.

3 **HDMI IN Port:** Connect to HDMI source equipment such as a media player, game console, or set-top box.

## 6.2 Rear Panel

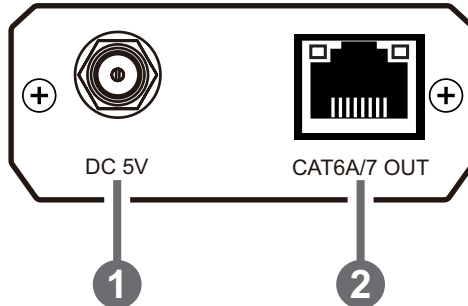

- 1 DC 5V Port:** Plug the 5V DC power adapter into this port and connect it to an AC wall outlet for power.

*Note: Optional, not required if the unit is powered via PoE.*

- 2 CAT6A/7 OUT Port:** Connect directly to a compatible receiver for Point-to-Point extension, or to a 10 Gigabit Ethernet switch for distributed matrixing (requires IP Master Controller or control software), with a single Cat.6A/7 cable for extension of all data signals.

*Note: If the connected network switch supports the IEEE 802.3af PoE (Power over Ethernet) standard, this unit can optionally be powered directly via this Ethernet port.*

## 6.3 Basic AV Extension

### 6.3.1 Point-to-Point (One Way)

The most basic extension configuration available is a point-to-point system with a single transmitter connected directly to a single receiver. In this configuration the HDMI input on the transmitter side is transmitted to the connected receiver side without modification to the audio or video format. The HDMI input supports 8 channels of LPCM audio, as well as bitstream and HD bitstream pass-through extension. This configuration is ideal for basic video extension.



*Note: This configuration does not use or require an external control centre such as the IP Master Controller to function. No audio insertion/extraction is performed in this configuration.*

## 6.4 Advanced AV Extension

### 6.4.1 IP Master Controller

The IP Master Controller is a hardware solution designed to provide a unified and easy method to access and control all of the transmitters and receivers in a system. It provides a user-friendly, and operating system agnostic, web-based interface allowing easy control over all of the most critical functions within a distribution system.

The IP Master Controller hardware is an optional component and is not included with individual transmitter, receiver, or transceiver units. Please contact your authorised dealer for more information.

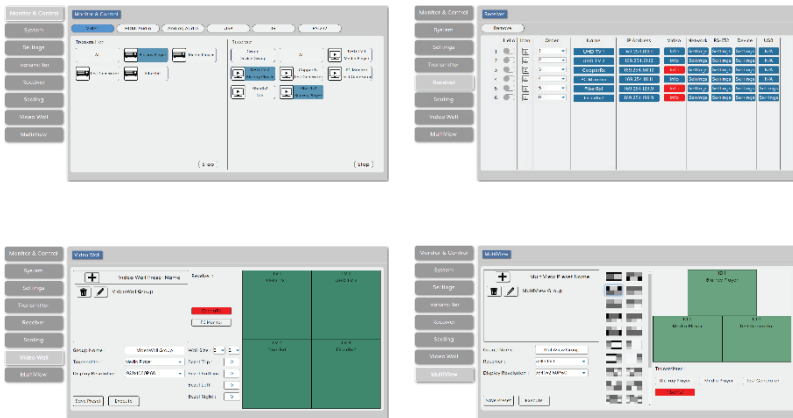

*Note: Interface images are for example only and may differ from the delivered product. Full operational documentation can be found within the IP Master Controller's manual.*

### 6.4.2 Configuration Examples

When combined with the IP Master Controller, and a 10 Gigabit Ethernet switch, this extension system gains a large number of additional configuration options including: multi-in/multi-out matrix switching with video wall creation, and a multiview output mode.

#### (1) Matrix Configuration

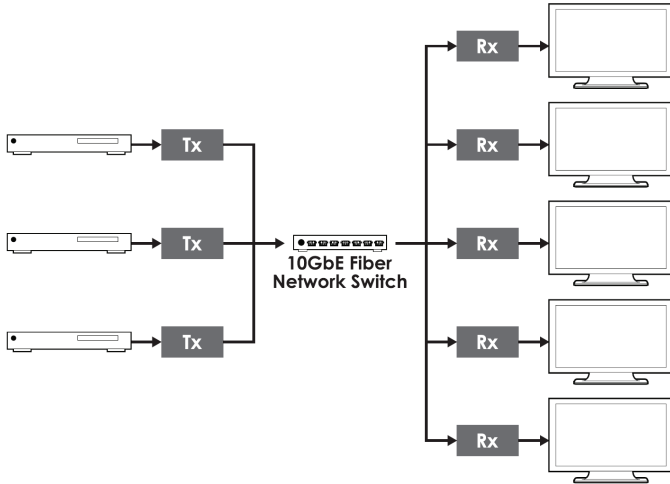

#### (2) Video Wall Configuration

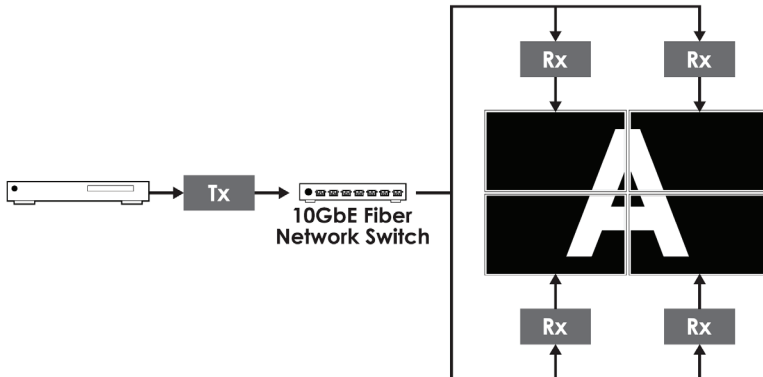

### (3) Multiview (PiP/PoP/Quad/Etc.) Configuration

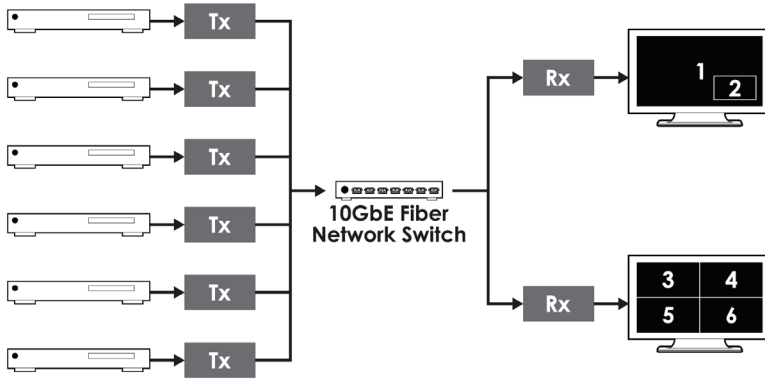

## 7. CONNECTION DIAGRAM

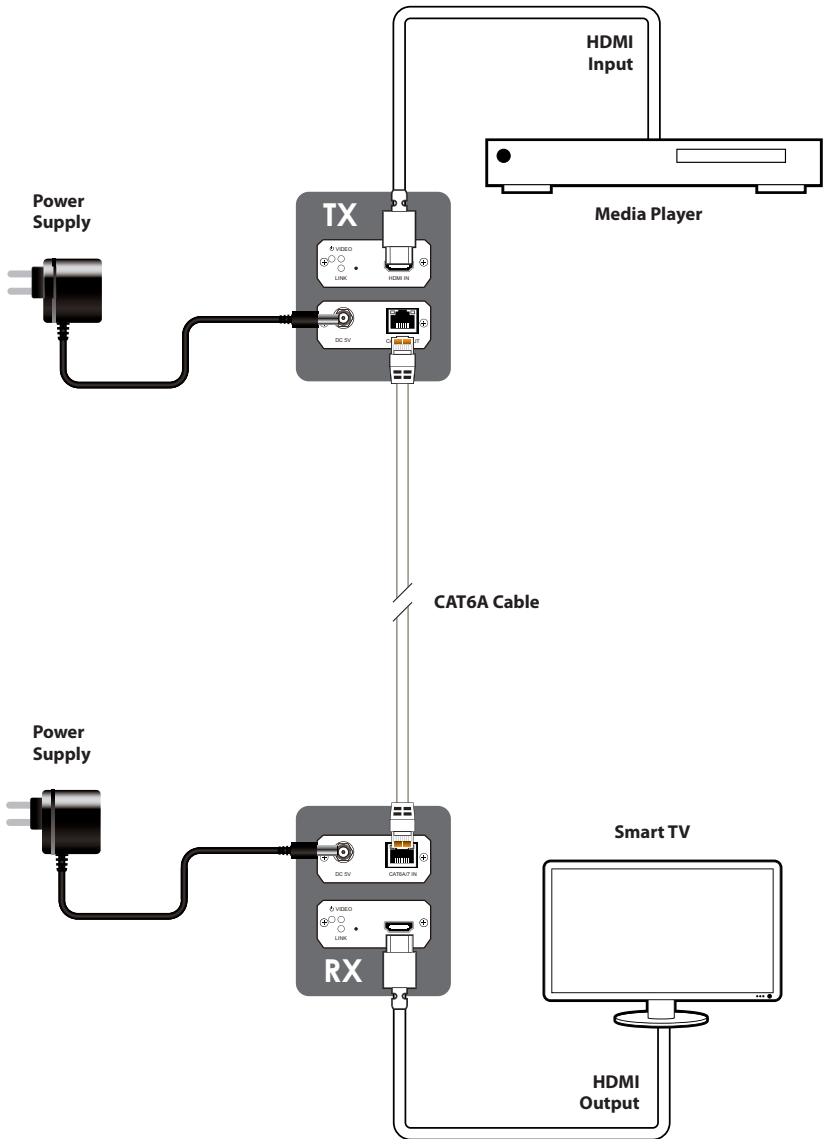

## 8. SPECIFICATIONS

### 8.1 Technical Specifications

<b>HDMI Bandwidth</b>	18Gbps
<b>CAT6A/7 Bandwidth</b>	10Gbps
<b>Input Port</b>	1×HDMI (Type-A)
<b>Output Port</b>	1×10GbE LAN (RJ-45)
<b>Power Supply</b>	PoE (802.3af) or 5V/2.6A DC (US/EU standards, CE/FCC/UL certified)
<b>ESD Protection (HBM)</b>	±12kV (Air Discharge) ±8kV (Contact Discharge)
<b>Dimensions (W×H×D)</b>	60mm×24.75mm×95mm [Case Only] 60mm×24.75mm×103mm [All Inclusive]
<b>Weight</b>	178g
<b>Chassis Material</b>	Metal (Aluminum)
<b>Chassis Colour</b>	Black
<b>Operating Temperature</b>	0°C – 40°C/32°F – 104°F
<b>Storage Temperature</b>	-20°C – 60°C/-4°F – 140°F
<b>Relative Humidity</b>	20 – 90% RH (Non-condensing)
<b>Power Consumption</b>	6.58W

## 8.2 Video Specifications

Supported Resolutions (Hz)	Input	Output
	HDMI	Cat.6A/7
<b>720×400p@70/85</b>	✓	✓
<b>640×480p@60/72/75/85</b>	✓	✓
<b>720×480i@60</b>	✓	✓
<b>720×480p@60</b>	✓	✓
<b>720×576i@50</b>	✓	✓
<b>720×576p@50</b>	✓	✓
<b>800×600p@56/60/72/75/85</b>	✓	✓
<b>848×480p@60</b>	✓	✓
<b>1024×768p@60/70/75/85</b>	✓	✓
<b>1152×864p@75</b>	✓	✓
<b>1280×720p@50/60</b>	✓	✓
<b>1280×768p@60/75/85</b>	✓	✓
<b>1280×800p@60/75/85</b>	✓	✓
<b>1280×960p@60/85</b>	✓	✓
<b>1280×1024p@60/75/85</b>	✓	✓
<b>1360×768p@60</b>	✓	✓
<b>1366×768p@60</b>	✓	✓
<b>1400×1050p@60</b>	✓	✓
<b>1440×900p@60/75</b>	✓	✓
<b>1600×900p@60RB</b>	✓	✓
<b>1600×1200p@60</b>	✓	✓
<b>1680×1050p@60</b>	✓	✓
<b>1920×1080i@50/60</b>	✓	✓

Supported Resolutions (Hz)	Input	Output
	HDMI	Cat.6A/7
<b>1920×1080p@24/25/30</b>	✓	✓
<b>1920×1080p@50/60</b>	✓	✓
<b>1920×1080p@100/120</b>	✓	✓
<b>1920×1200p@60RB/60</b>	✓	✓
<b>2560×1440p@60RB</b>	✓	✓
<b>2560×1080@50/60</b>	✓	✓
<b>2560×1600p@60RB</b>	✓	✓
<b>2048×1080p@24/25/30</b>	✓	✓
<b>2048×1080p@50/60</b>	✓	✓
<b>3840×2160p@24/25/30</b>	✓	✓
<b>3840×2160p@50/60 (4:2:0)</b>	✓	✓
<b>3840×2160p@24, HDR10</b>	✓	✓
<b>3840×2160p@50/60 (4:2:0),HDR10</b>	✓	✓
<b>3840×2160p@50/60</b>	✓	✓
<b>4096×2160p@24/25/30</b>	✓	✓
<b>4096×2160p@50/60 (4:2:0)</b>	✓	✓
<b>4096×2160p@24, HDR10</b>	✓	✓
<b>4096×2160p@50/60 (4:2:0),HDR10</b>	✓	✓
<b>4096×2160p@50/60</b>	✓	✓

## 8.3 Audio Specifications

### 8.3.1 Digital Audio

HDMI Input	
LPCM	
<b>Max Channels</b>	8 Channels
<b>Sampling Rate (kHz)</b>	32, 44.1, 48, 88.2, 96, 176.4, 192
Bitstream	
<b>Supported Formats</b>	Standard & High-Definition
10GbE Output	
LPCM	
<b>Max Channels</b>	8 Channels
<b>Sampling Rate (kHz)</b>	32, 44.1, 48, 88.2, 96, 176.4, 192
Bitstream	
<b>Supported Formats</b>	Standard & High-Definition

## 8.4 Cable Specifications

Cable Length	HD	FHD	4K UHD	4K UHD+	8K UHD
<b>High Speed HDMI Cable</b>					
<b>HDMI Input</b>	<b>15m</b>	<b>10m</b>	<b>5m</b>	<b>3m</b>	<b>×</b>
<b>Ethernet Cable</b>					
<b>Cat.6A/7 Output</b>	<b>100m</b>				

### Bandwidth Category Examples:

- **HD Video**
  - 720p@60Hz
  - HDMI transmission rates lower than 3Gbps
  - HD-SDI (SMPTE 292M, 1.485Gbps)
- **FHD Video**
  - 1080p@60Hz
  - HDMI transmission rates between 3Gbps and 5.3Gbps
  - 3G-SDI (SMPTE 424M, 2.970Gbps)
- **4K UHD Video**
  - 4K@24/25/30Hz (8-bit colour) & 4K@50/60Hz (4:2:0, 8-bit colour)
  - HDMI transmission rates between 5.3Gbps and 10.2Gbps
  - 6G-SDI (SMPTE ST 2081, 6Gbps)
- **4K UHD+ Video**
  - 1080p@120Hz (10/12-bit HDR)
  - 4K@50/60Hz (4:4:4, 8-bit) & 4K@50/60Hz (4:2:0, 10/12-bit HDR)
  - HDMI transmission rates between 10.2Gbps and 18Gbps
  - 12G-SDI (SMPTE ST 2082, 12Gbps)
- **8K UHD Video**
  - 4K@120Hz (10/12-bit HDR)
  - 8K@24/25/30Hz (10/12-bit HDR) & 8K@50/60Hz (4:2:0, 8-bit colour)
  - HDMI transmission rates between 18Gbps and 48Gbps
  - 24G-SDI (SMPTE ST 2083, 24Gbps)

## 9. ACRONYMS

ACRONYM	COMPLETE TERM
<b>10GbE</b>	10 Gigabit Ethernet
<b>4K UHD</b>	4K Ultra-High-Definition (10.2Gbps max)
<b>4K UHD+</b>	4K Ultra-High-Definition (18Gbps max)
<b>ADC</b>	Analogue-to-Digital Converter
<b>AVoIP</b>	Audio/Video over IP
<b>Cat.5e</b>	Enhanced Category 5 cable
<b>Cat.6</b>	Category 6 cable
<b>Cat.6A</b>	Augmented Category 6 cable
<b>Cat.7</b>	Category 7 cable
<b>DAC</b>	Digital-to-Analogue Converter
<b>dB</b>	Decibel
<b>DHCP</b>	Dynamic Host Configuration Protocol
<b>EDID</b>	Extended Display Identification Data
<b>GbE</b>	Gigabit Ethernet
<b>Gbps</b>	Gigabits per second
<b>HD</b>	High-Definition
<b>HDCP</b>	High-bandwidth Digital Content Protection
<b>HDMI</b>	High-Definition Multimedia Interface
<b>HDR</b>	High Dynamic Range
<b>HDTV</b>	High-Definition Television
<b>IEEE</b>	Institute of Electrical and Electronics Engineers
<b>IGMP</b>	Internet Group Management Protocol
<b>IP</b>	Internet Protocol
<b>kHz</b>	Kilohertz

<b>ACRONYM</b>	<b>COMPLETE TERM</b>
<b>LAN</b>	Local Area Network
<b>LED</b>	Light-Emitting Diode
<b>LPCM</b>	Linear Pulse-Code Modulation
<b>MAC</b>	Media Access Control
<b>MHz</b>	Megahertz
<b>PD</b>	Powered Device
<b>PiP</b>	Picture in Picture
<b>PoP</b>	Picture outside of Picture
<b>SFP</b>	Small Form-factor Pluggable transceiver
<b>SDVoE</b>	Software Defined Video over Ethernet
<b>SNR</b>	Signal-to-Noise Ratio
<b>TCP</b>	Transmission Control Protocol
<b>THD+N</b>	Total Harmonic Distortion plus Noise
<b>TMDS</b>	Transition-Minimised Differential Signaling
<b>UAC</b>	USB Audio Class
<b>UHDTV</b>	Ultra-High-Definition Television
<b>VoIP</b>	Video over IP
<b>WUXGA (RB)</b>	Widescreen Ultra Extended Graphics Array (Reduced Blanking)
<b>XGA</b>	Extended Graphics Array
<b>Ω</b>	Ohm







---

CYP (UK) Ltd., Unit 7, Shepperton Business Park, Govett Avenue,  
Shepperton, Middlesex, TW17 8BA

Tel: +44 (0) 20 3137 9180 | Email: [sales@cypeurope.com](mailto:sales@cypeurope.com)

[www.cypeurope.com](http://www.cypeurope.com)

v1.00